

## Parallel Dual Battery Installation

On dual battery vehicles, only one *PriorityStart!* unit is required. Please make sure the batteries are in "Parallel" set-up – i.e., two 12-volt batteries cabled together from positive to positive, and negative to negative.

**Important Note:** The cable connecting both batteries ("Direct Cable between Battery 1 To Battery 2" - as shown below) must remain separate from the cable deriving from the starter. If one cable is used, it must be separated into two. The cable (connecting both batteries) should not be moved to the top post of the P/S! It should stay on the actual posts of both batteries.

See Diagram below:

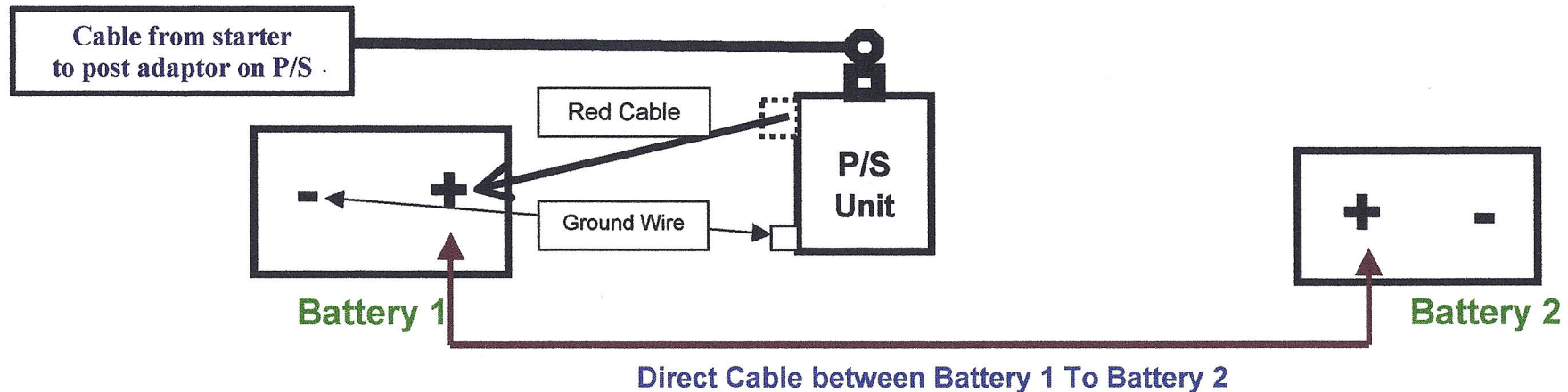

The P/S can handle up to 1000 starting amps. (Amps that the *starter* draws).

**Very important to follow this note:** Individual accessories that have separate wiring would *a/so* be moved to the top of the P/S. Remember the P/S is now monitoring everything through the cable and so would pick up everything attached to it.

You may now proceed to install as shown in *the green and white owner's manual* that is included with each purchase (and listed on our website [www.prioritystart.com](http://www.prioritystart.com) - section: "Documentation"). This simple installation will explain in what order to attach the *PriorityStart!*.