

Series 24-Volt Dual Battery Installation

On dual batteries vehicles only one *PriorityStart!* unit is required; the P/S can handle 1000 cranking amps (*cranking amps are starter amps*). First step is to *firmly* install the U-clip by itself to negative post on battery ONE. PriorityStart! unit is installed on battery TWO, as shown in the below illustration.

Attach the terminal connector end of the starter cable to the top of the PS (this attachment is critical, and must be done tightly to maintain good continuity).

Accessories would connect the same way they were. Remember the PS is now monitoring everything through the cable and so would pick up everything attached down line.

Final step is to connect black ground wire from P/S to U-clip on negative post on battery ONE.

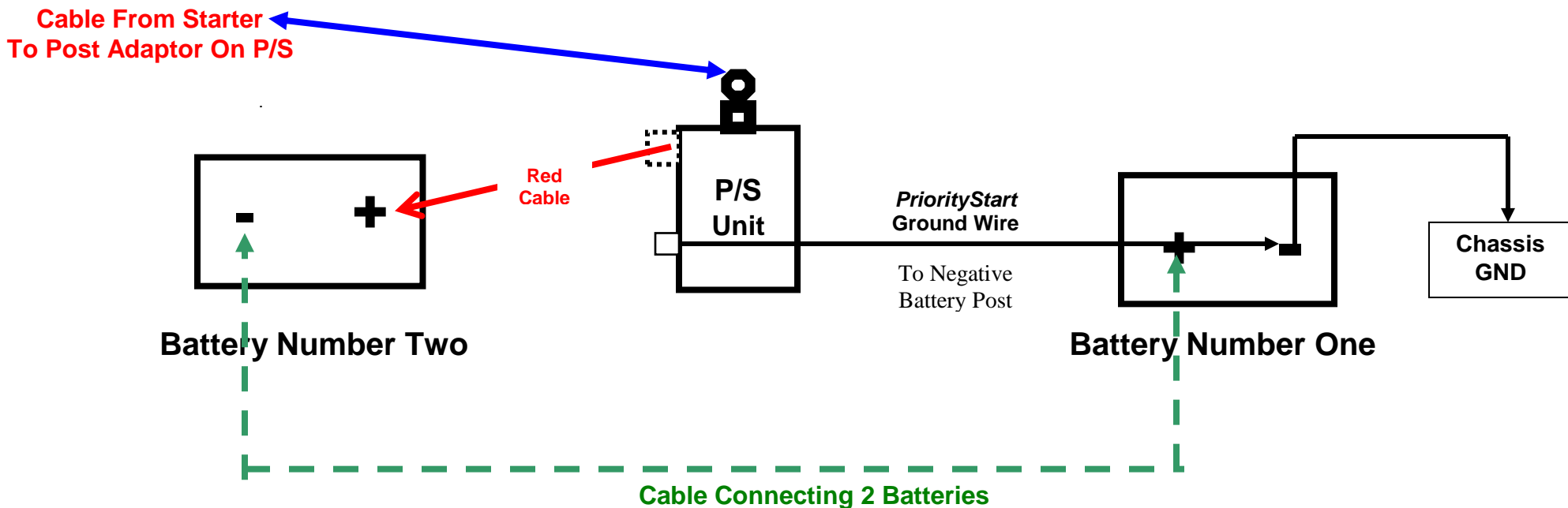

Important Note: The cable connecting both batteries ("**Cable Connecting 2 Batteries**") must remain separate from the cable deriving from the starter. If one cable is used, it must be separated into two. The cable (connecting both batteries) should not be moved to the top post of the P/S! It should stay on the actual posts of both batteries.